



# DESIGN & CONSTRUCTION SUGGESTIONS

Designing a System is Easier Than You Might Think.  
Radiantec Will Help. Call Us for Assistance With Your Design.

1-800-451-7593



## TABLE OF CONTENTS

1. Radiant Heating Methods (new and retrofit)
2. Estimate Your Heating Needs
3. Insulate for Best Efficiency
4. Select the Right Heat Source
5. Select the Right Tubing

Additional Information is available

Look on the Internet for the following subjects:

[www.radiantec.com](http://www.radiantec.com) (select installation manual) or call 1-800-451-7593

Install radiant heat within a slab  
 Install radiant heat within floor joists  
 Install radiant heat in a ceiling  
 Decide about heating zones  
 Working with installation packages

Wiring and controls  
 Snowmelting  
 Tubing layout  
 Towel racks  
 Tool lists

### INSTALLATION SUPPLEMENT 230—Install a “closed” radiant heating system

Install a heating system that is completely self-contained and not connected to anything else. Installation packages, tool lists, etc.

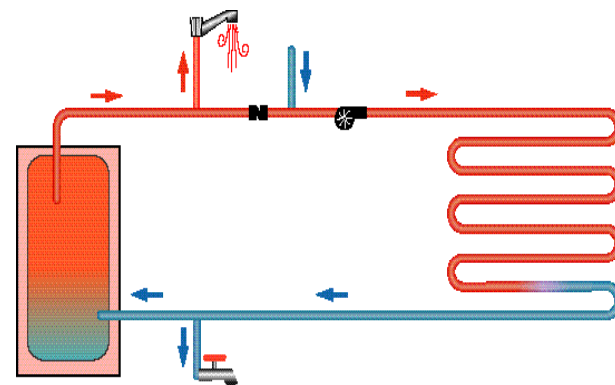
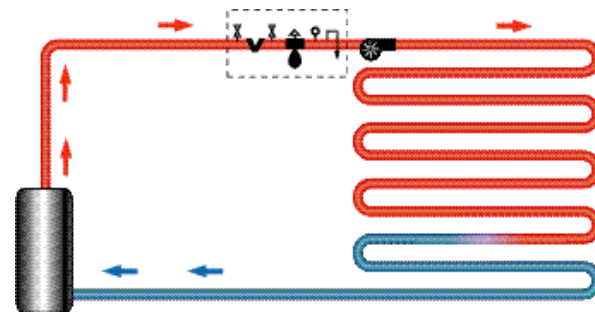

### INSTALLATION SUPPLEMENT 220—Install the Radiantec Open Direct System (using a domestic hot water heater)

Install the simplest and most efficient heating system available. Installation packages, tool lists, etc.

### INSTALLATION SUPPLEMENT 240—Install an “indirect” radiant heating system with a heat exchanger

Separate the heating fluid from the domestic hot water, or add a snowmelt system.

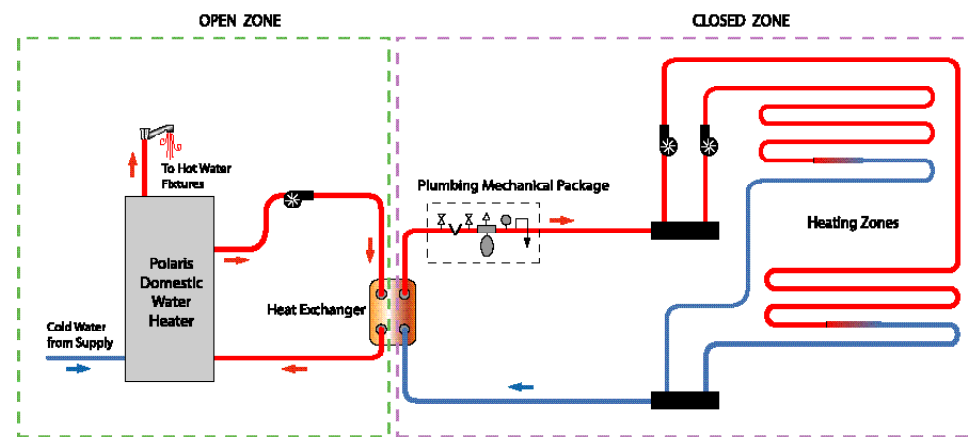

INSTALLATION SUPPLEMENT 280—Install radiant within walls-Radiant wall heating can be used to supplement the building’s heating needs if there is doubt that floor heating alone will be adequate.

INSTALLATION SUPPLEMENT 290—Install radiant within ledger-The ledger method is attractive in a retrofit situation when it is not desirable to raise the finish floor level.

INSTALLATION SUPPLEMENT 295—Install a heated towel rack-For the ultimate in bathroom luxury.

GENERAL SUPPLEMENT 410—Install the controls for a radiant heating system-Learn how to install the simple controls that Radiantec uses for high efficiency.

GENERAL SUPPLEMENT 440—Tubing Layouts-Radiantec Company will provide all the help that you want in coming up with a good layout for your project.



Copyright 2003, Robert J. Starr

Revised on  
1/28/04

# RADIANT HEATING METHODS

There are many ways to use radiant heating and/or cooling. Here are some of the more common methods.

PLEASE NOTE THAT SOME OF THESE METHODS ARE ABLE TO PUT OUT MORE HEAT THAN OTHERS.

**R** = a retrofit possibility

**SLABS ON GRADE** – A high efficiency method with very high heat output. (50-90 BTU per hour per square ft)

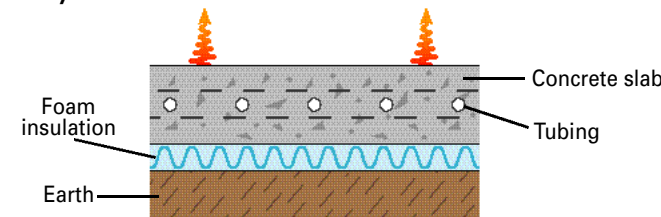

**SUSPENDED SLABS** – A slab is cast over floor joists. This is a way to gain high performance with a joisted floor. **R** (50-90 BTU per hour per square ft)

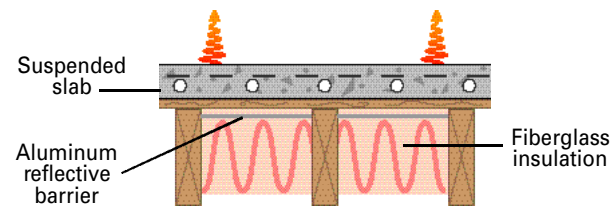

**TOPPING SLABS** – A slab containing heating tubes is cast over an existing slab. **R** (50-90 BTU per hour per square ft)

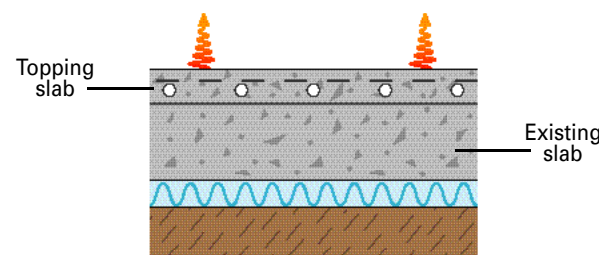

**WITHIN JOISTED FLOORS** – Tubing is stapled to the underside of the floor from beneath. **R** (up to 45 BTU per hour per square ft)

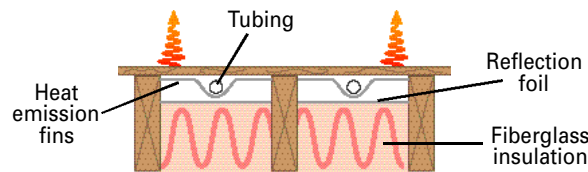

**CEILING** – Tubing is placed between strapping underneath the ceilings. (40-50 BTU per hour per square ft)

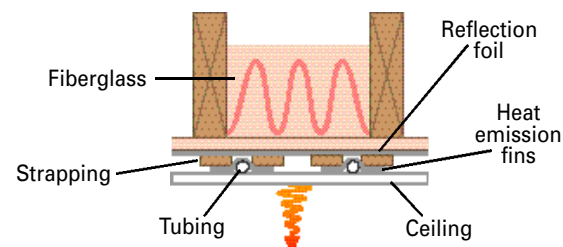

**LEDGER** – Tubing is placed upon a ledge within the joist space. This is a common retrofit solution when building up the floor is not practical. **R** (up to 45 BTU per hour per square ft)

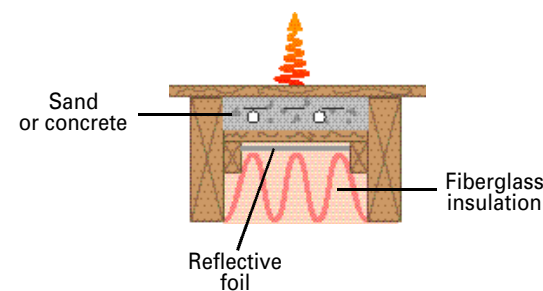

**BETWEEN STRAPPING** – Tubing is placed in the space between wooden strapping members. If the space is filled with concrete or drymix, the method offers most of the performance of slabs, and yet allows wooden flooring to be placed on top. A good way to heat a “great room” with high heat requirements. (50-80 BTU per hour per square ft)

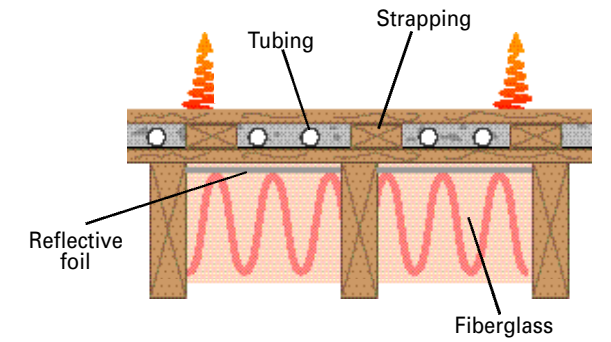

**WITHIN THE SUBFLOOR** – The subfloor is precut or notched to accommodate the tubing. Another possibility if the floor level cannot be raised. **R** (up to 40 BTU per hour per square ft)

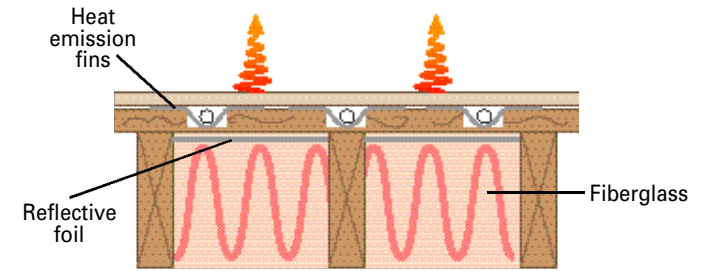

**WITHIN THE WALLS** – Tubing is placed within the cavity of a partition wall. Exceptional comfort results if the floor and walls are heated in a bathroom. Combine wall heating with towel warmers. (50-80 BTU per hour per square ft)

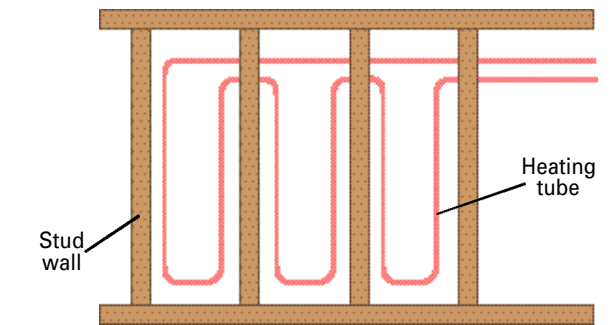

## RADIANT COOLING OPTIONS

Radiant cooling is efficient and practical. Here is a good method. Radiant cooling does not dehumidify the air as “air conditioning” does; it only cools. This is a benefit in some ways, but a potential problem in other ways. When one surface, such as the floor is cooled, it will have the effect of cooling the entire building because the surface will gain radiant energy from all other surfaces in the building, and in the process, cool them as well.

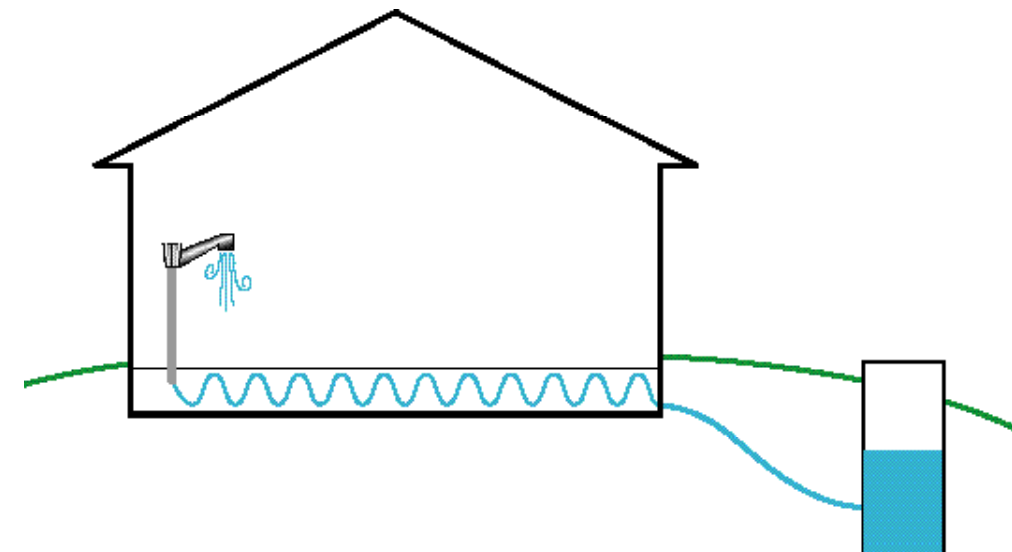

# ESTIMATE YOUR HEATING REQUIREMENTS

Underfloor radiant heat uses the floor to heat the building above by raising the floor in temperature until the heating output of the floor matches the amount of heat that the building is losing. We need to estimate the heat loss of the building so that we can estimate the floor temperature that will be needed to do the job. Then we can go about the task of deciding which radiant method to use and what the tube spacing and fluid temperatures should be in order to do the job in the most efficient manner.

INSULATING VALUE OF THE BUILDING	HEAT LOSS in BTU's PER HOUR PER SQUARE FT. (BTU's/HOUR/DEGREE F)
<b>SUPER INSULATED</b> (very high R values: R=30 walls, R=50 ceilings, high performance windows, .25 air changes per hour or better, exceeds modern energy codes)	<b>.1 BTU's</b> per hour per square ft. of floor area, per °F
<b>GOOD</b> (high R values: R=19 walls, R=38 ceilings, high performance windows, tight construction, typical of new buildings meeting modern energy codes)	<b>.3 BTU's</b> per hour per square ft. of floor area, per °F
<b>FAIR</b> (typical of well maintained existing structures)	<b>.6 BTU's</b> per hour per square ft. of floor area, per °F
<b>POOR</b> (poorly insulated, leaky construction)	<b>2.0 BTU's</b> per hour per square ft. of floor area, per °F, or more.

**EXAMPLE:** What is the heat loss (per square foot) of a building with "good" insulating characteristics when it is 65° inside and -10° outside?  
**ANSWER:** 22.5 BTU's/hr/ft<sup>2</sup> (heat loss x temperature difference) (.30 btu's/hr/ft<sup>2</sup>/degree f x 75° f)

**DEFINITION:** BTU stands for British Thermal Unit and is the amount of heat needed to raise one pound of water one degree Fahrenheit.

## DETERMINE THE HEATING REQUIREMENT PER SQUARE FOOT

The chart on the right is a rough "rule of thumb" guide for assessing a building's heat loss. It does not take the place of a heat loss analysis but can be useful in making preliminary decisions. Your Radiantec Co. representative will provide design assistance as part of his or her services.

## MULTIPLY HEAT LOSS BY TEMPERATURE DIFFERENCE

The chart below shows that a floor temperature of 80°F will be adequate to put out 27 BTU's per hour. This will be enough to heat a building with "good" insulation when it is well below zero. Nearly all residential buildings and most commercial buildings are built to this standard today.

Multiply your heat loss per square foot by the area (in square feet) of your building:

You will need a heater or boiler with this rated output. Your contractor should confirm this calculation.

## DETERMINE YOUR HEAT OUTPUT

Use the graphs on the following page to predict the amount of heat that you will get from the floor. Heating outputs greater than 45 BTU's per hour cannot be achieved without floor temperatures greater than 90°F. Use supplementary heat in those rare cases where more than 45 BTU's/square ft are required or better still, invest in energy conservation measures. Radiant ceiling heat, when used as a supplement, will provide exceptional comfort.

Use this chart to see what the temperature of the floor must be in order to heat the building when the outside air is of the coldest expected (design temperature)

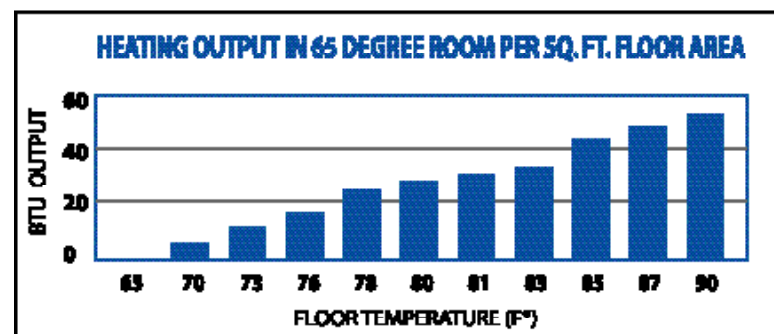

# HEAT OUTPUT PER SQUARE FT. OF FLOOR AREA

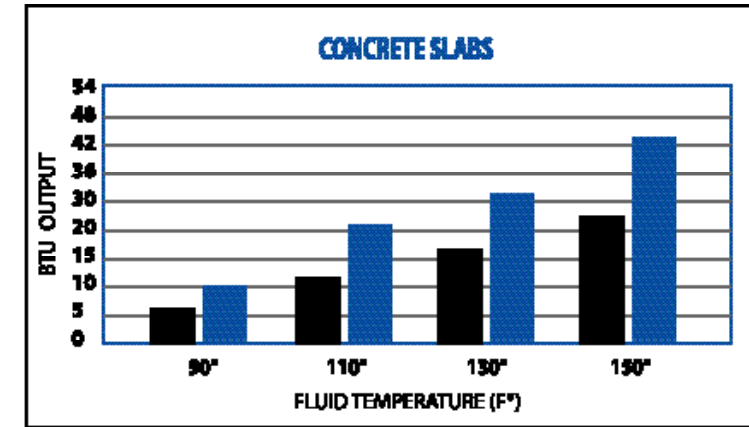

■ Carpet (3/4" carpet, 1/4" pad) ■ Non-Carpet  
 ASSUME THE FOLLOWING TUBE SPACING:  
 7/8" POLY PEX - 16" on center  
 1/2" PEX - 12" on center  
 3/8" PEX - 8" on center

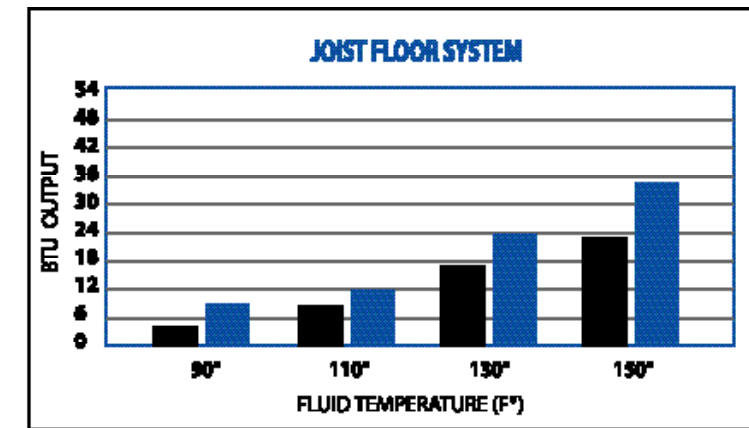

■ Carpet (3/4" carpet, 1/4" pad) ■ Non-Carpet  
 ASSUME THE FOLLOWING TUBE SPACING:  
 7/8" POLY PEX - 16" on center  
 1/2" PEX - 8" on center  
 3/8" PEX - 6" on center

## WHAT SHOULD YOU DO IF YOU ARE NOT SURE THAT YOU WILL GET ENOUGH HEAT FROM THE RADIANT FLOOR.

This happens occasionally and there are several solutions.

1. Lower the heat loss with energy efficiency measures. (This is the best solution.)
2. Look at another radiant heating method that puts out more heat than what you were thinking about first. A slab or suspended slab will put out more heat than joisted floors.
3. Use a supplement for very cold days, like a woodstove or gas fireplace.
4. Use supplemental radiant wall heat or radiant ceiling heat. (very comfortable)
5. Use supplemental baseboard heat.

# INSULATION METHODS

**SLAB ON GRADE** - It is helpful to understand the nature of heat loss to the ground so that we can plan good strategies to reduce it. Very little heat is lost straight down with a slab on grade structure. Earth is not a very good insulator, but there is a great thickness of it so that heat does not penetrate much more than 4 feet. Of greater concern is heat loss off to the sides, and for that reason, we concentrate the insulation efforts there.

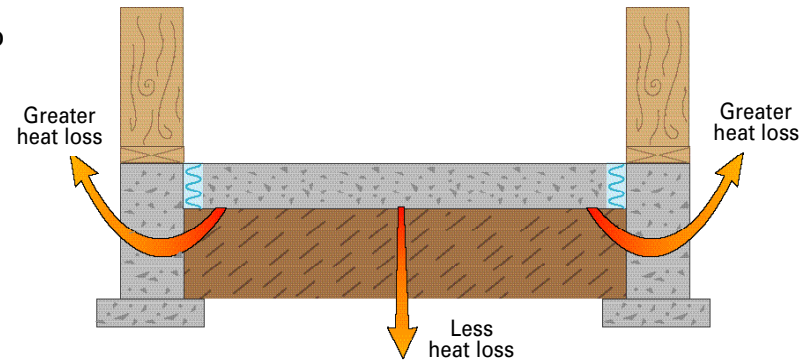

The proper material for below grade insulation is extruded polystyrene. Other materials are prone to absorb moisture or do not have enough compressive strength or stability over time. There is no substitute at present.

You can insulate either vertically down the side of the building or you can insulate horizontally under the slab. The methods are about the same as far as reducing heat loss is concerned.

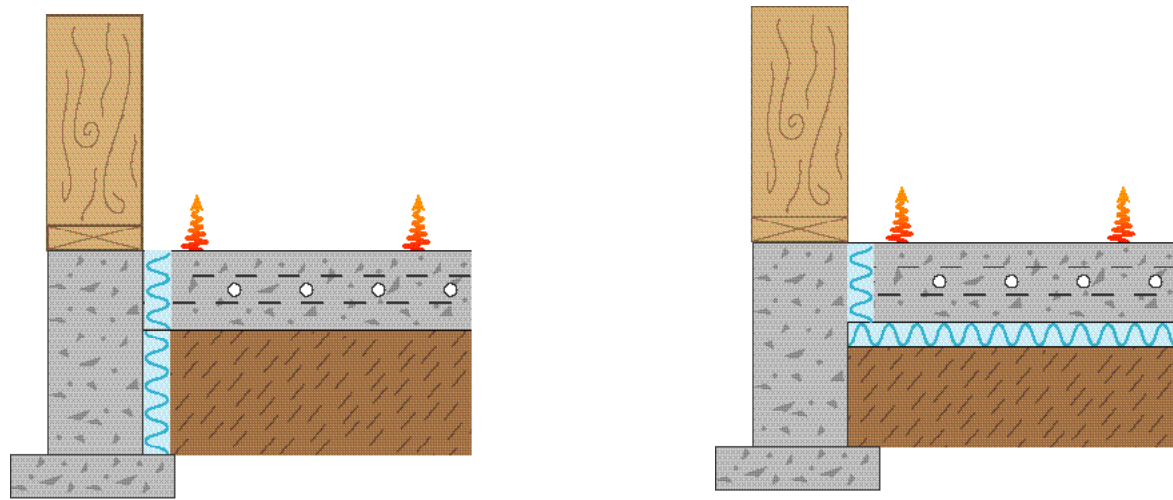

But the choice of insulation method can make a big difference in the ability of the building to store heating or cooling energy.

If the insulation is placed vertically, the heat storage ability of the earth is incorporated into the building down to an effective depth of about 3 feet. This results in a building that can store large quantities of heating or cooling energy. Such a building can "coast" through the Spring and Fall seasons without large amounts of heating or cooling energy inputs. Such a building can also be designed to store alternative energies such as solar, in an efficient and cost effective way.

On the other hand, the building with vertical insulation will not be as responsive to changes in energy inputs as compared to the building with a horizontal placement under the slab. There will be less benefit from nighttime or weekend temperature setbacks.

Larger sized slab on grade buildings can benefit from a special detail with the benefits of both insulation methods.

Larger sized slab on grade buildings should use this detail.

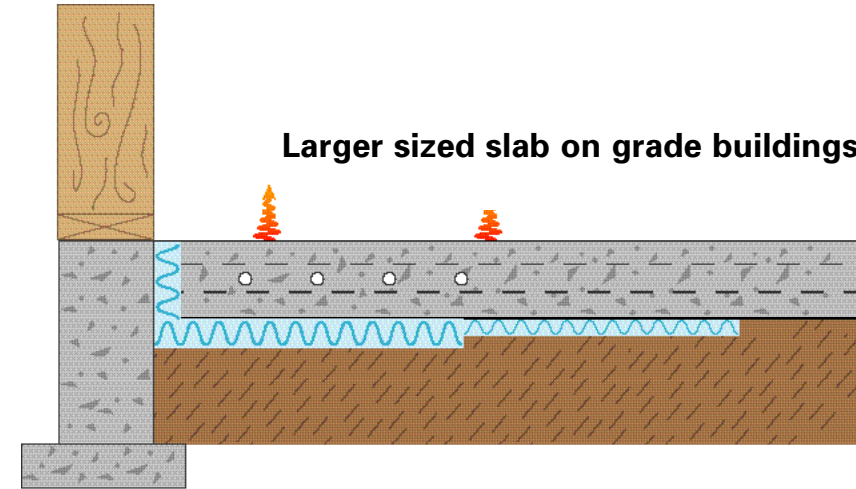

Insulation of decreasing thickness is placed from the perimeter of the slab in towards the middle of the building. It is common to use 2" thick polystyrene for 4 ft and then 1" thick for another 4 ft and then no insulation at all under the center of the slab. The method reduces heat loss and also creates a heat storage mass. The building will be responsive to thermostat changes and will require less insulation material.

**JOISTED STRUCTURES** - The extent of the insulation measures depends upon what the consequences of the heat losses are. For example, if heat loss downward is entirely wasted, such as to a crawl space, then insulation should be extensive. If heat loss downward will go to another area that also needs heat, the insulation effort can be less extensive. Be careful not to permit so much heat loss downward that the area where the heat is wanted does not get enough. If there is extensive carpeting above, there needs to be more insulation beneath the heated floor.

Within joisted structures, there are three approaches 1) fiberglass batt insulation, 2) an aluminum reflective foil surface and 3) a foam panel.

This detail is good for crawl spaces and other situations where no heat loss downward at all is wanted. The aluminum reflective foil reflects radiant heat energy upwards. The fiberglass batt controls conducted energy downwards and the foam insulation board adds more R value, insulates the joist and keeps out the wind.

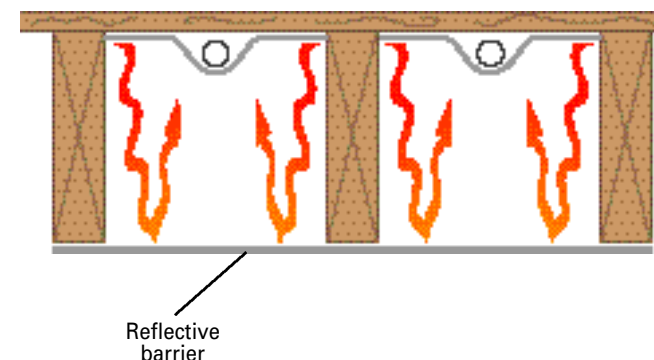
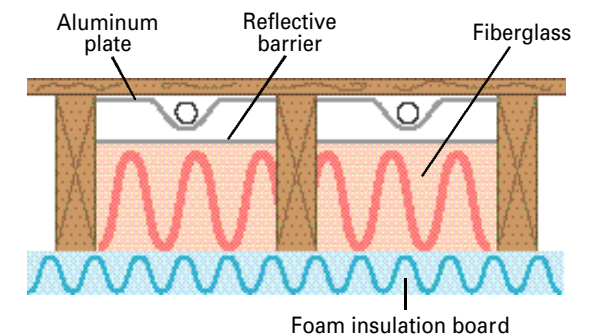

This detail ensures that most (but not all) of the heat given off by the floor will go up. An aluminum foil reflective barrier reflects radiant heat that is headed downward back up to the floor. The air in the joist space works as insulation because it is "trapped" by thermal layering. The effectiveness of the aluminum foil can be lowered by dust accumulation. Plastic sheeting or rosin paper can be applied under the finish floor to eliminate dusting.

## SELECT THE RIGHT HEATING SYSTEM

**A CLOSED SYSTEM** - is one in which the heating fluid is self contained within the system and stays there unless removed for maintenance. A boiler or water heater warms the water (or another fluid such as anti-freeze). When heat is called for by the thermostat, a pump comes on and circulates the warm water throughout the floor until the thermostat is satisfied. A package of plumbing mechanical device is needed for proper operation. These devices include fill and drain valves, flow control valves, an air eliminator, pressure relief valve, pressure gauge, an air eliminator, and an expansion tank. **Closed systems are familiar to code officials and contractors, and they encounter little resistance. Closed systems can be combined with baseboard radiators.**

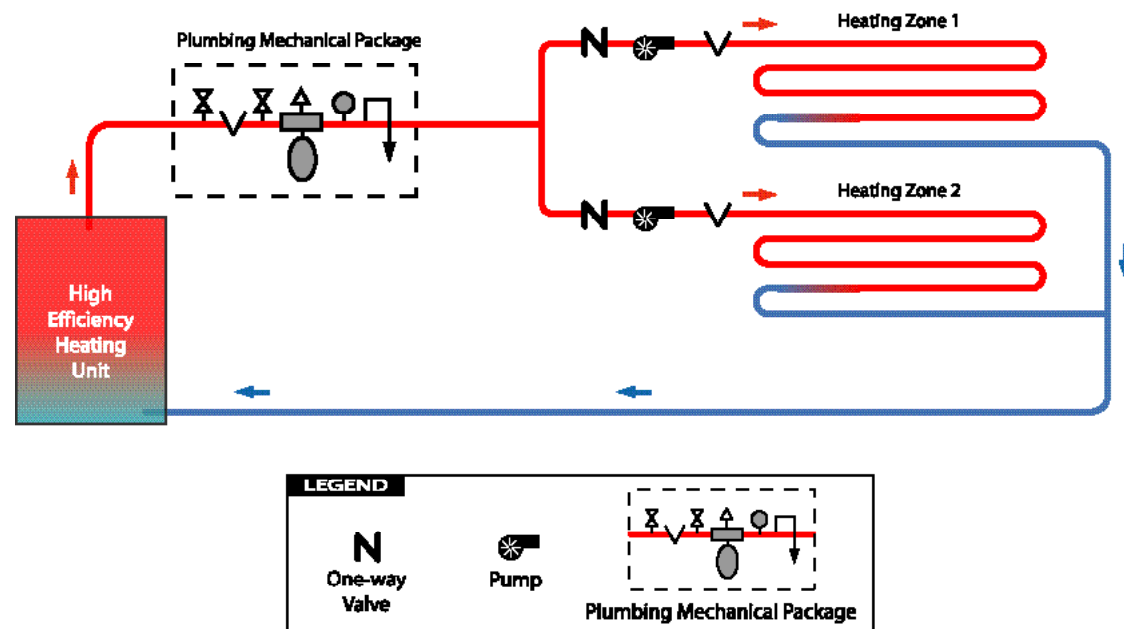

## USE THE SAME HEATING UNIT FOR BOTH HEATING AND DOMESTIC HOT WATER

There are many reasons to do this in residential construction, and few reasons not to. The energy efficiency and cost efficiency are both excellent. Most domestic hot water heaters do nothing at all for 22 hours per day. Most water heaters easily have capacity to do both. All heating units waste considerable energy when they are just "standing by". When you use one unit to do two jobs, the standby losses of one unit are eliminated and the one combined unit stands by less often. When you buy one good, highly energy efficient unit to do the work of two lesser units, your energy bill can drop by 40% or more. These systems are called Radiantec Open Direct systems

## THE RADIANTEC OPEN DIRECT SYSTEM

The Radiantec Open Direct System uses the domestic hot water heater to provide both underfloor heating and domestic hot water from the same unit. In the heating mode hot water flows directly from the water heater, through the heating tubes, and back to the heater. This is a highly efficient system with many significant advantages.

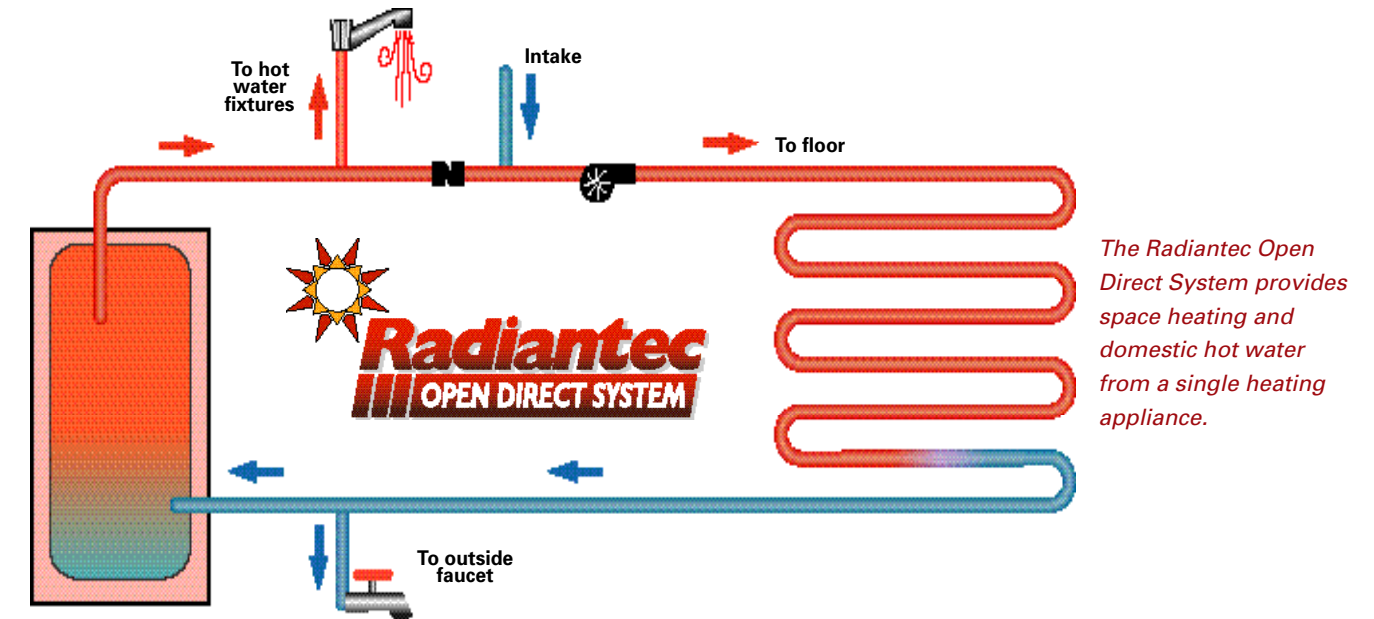

## FLOW

- When heat is called for, the pump comes on and water flows out of the top of the tank, through the heating zone and back to the bottom of the tank.
- When domestic hot water is consumed, water flows out of the top of the tank to the point of use. Cold water replaces the hot water by flowing in at the top of the system, through the heating system, and then into the bottom of the tank.
- Visit our website at [www.radiantec.com/opendirect.htm](http://www.radiantec.com/opendirect.htm) to view animations of the Pioneer Comfort System in operation.

## REASONS

- The possibility of stagnation (particularly in the summer when the heat is not used) is absolutely eliminated.
- Incredible efficiency. During the summer, limited free cooling is enjoyed. Heat is taken out of the building (saving on the air conditioning bill). The heat is put in the domestic hot water tank (saving again on the gas bill!)
- In the winter, this flow pattern gives priority to the domestic hot water use if both heat and hot water are called for at the same time (so the person in the shower doesn't run out). There is no efficiency loss in the winter; any heat taken out of the floor is put in the tank so there is no net energy loss to the system.

The Radiantec Company has played a leading role in the development of these systems.

## ADVANTAGES

1. Very low cost.
2. Mechanically very simple, elegant and reliable.
3. Outstanding energy efficiency, particularly if the Polaris water heater is used.
4. Oxygen diffusion issues are not relevant.
5. Use of the outside faucet for watering lawns, etc. will further enhance cooling.

## ISSUES

1. The water must be kept potable and fit to drink. The flow detail described on page 9 must be executed and all materials used in the system must be potable rated.
2. Check with your local codes; waivers may be needed. Ask Radiantec Co. for assistance.
3. An expansion tank may be needed if check valves or backflow preventers prevent expansion water from backing up to the rest of the water system.
4. Be sure the system pressure is compatible with tubing pressure limits.

## THE INDIRECT SYSTEM

The indirect system uses a heat exchanger to separate the heating fluid from the domestic hot water. An advantage is that an antifreeze solution may be added to the heating fluid, and snow melting can be added to the system. Some code administrators may require the heat exchanger. A disadvantage is that the cooling benefit is eliminated. Also, cost and complexity are increased with the addition of the heat exchanger.

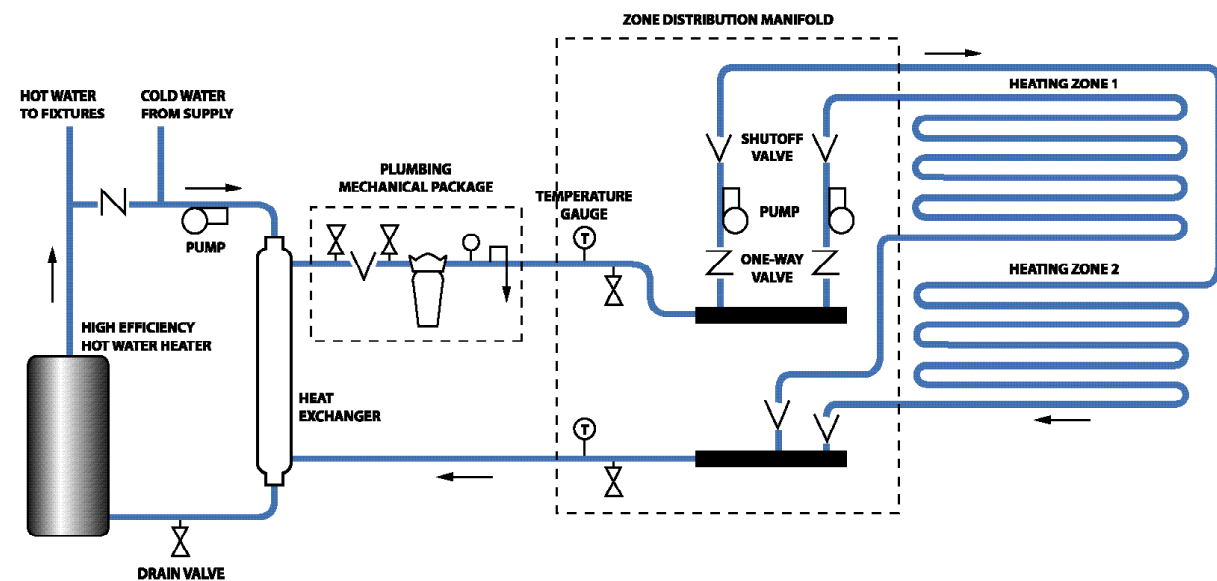

## SELECT THE RIGHT HEATING UNIT

Get the highest possible efficiency at a reasonable price.

Radiantec recommends that most people should use a water heater instead of a boiler. Radiant heat only requires water temperatures between 110<sup>0</sup>F and 150<sup>0</sup>F, and water heaters are designed to operate in these ranges. On the other hand, boilers are made to operate at very high temperatures and often will not work well at lower temperatures. Boilers often require expensive controls and mixing valves in order to provide lower temperature water.

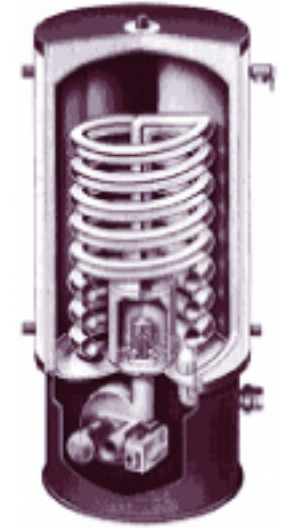

*The Polaris water heater is all stainless steel, 95+ efficient and vents with plastic pipe.*

There are significant efficiency advantages to low temperature operation. Your heater should be 95% efficient or better. The exhaust gas should be so cool that the unit can vent with plastic pipe instead of into an expensive chimney.

Domestic hot water heaters are designed to resist corrosion and attack by oxygen. DHWs can provide quite high initial heating outputs because of the combination of the burner output and the heat stored within the tank.

Also, a high quality hot water heater should cost thousands less than the equivalent boiler and controls.

## SELECT THE RIGHT TUBING

Because there are many different ways to use radiant heat, there are different types of heat exchanger tubing available. They all have slightly different properties and features. Here are some of the important considerations.

- The tubing should last a long time.
- The tubing should be strong enough.
- The tubing must have adequate heat output.
- The tubing must be easy enough to work with.
- The tubing may need to be acceptable by your local code official.
- The tubing may need to be potable rated.

The technicians at Radiantec will help you select the best tubing for your project. If you need specialty tubing that Radiantec does not offer, our technicians will say so and tell you where you can obtain it.

**TUBING TYPES:**

**7/8" POLY PXC** - POLY PXC tubing is a very high density polyethylene tubing that was developed under grant support from the United States Department of Energy and the National Bureau of Standards more than 20 years ago.

All polyethylene tubes have very long service lives and exceptional resistance to chemical attack. POLY PXC has the best overall heating performance and puts out twice as much heat as most other products. It has a slightly thinner wall and a temperature and pressure rating of 150<sup>0</sup> F @ 50 psi, which is lower than some products, but more than adequate for most applications. Poly PXC is available in 400 ft. lengths.

The bending radius is 12" (i.e. it will take 24 inches to make a 180<sup>0</sup> turn). The larger bending radius will not pose difficulty in a slab of reasonable size or within floor joists that are spaced 16" apart. However, you may need to select smaller tubing in cluttered retrofit situations. If you are subject to stringent building codes, it is always best to get approval before installation.

**7/8" SOLAR PEX** - This new product has the same overall shape and wall thickness as POLY PXC and its thermal performance is similar. A slightly different chemical formulation results in somewhat higher temperature and pressure ratings. This material has been produced and in service for about 2 years. Poly PEX is not certified under ASTM 877/876, but it does carry a NSF rating. Again, if you are subject to stringent building codes, it is always best to get approval before installation.

**3/4" PEX** - This product has thicker walls than the other tubings above and has higher temperature and pressure ratings (180<sup>0</sup> F @ 100 psi). However the thicker walls mean that the product is much less effective as a heat exchanger. 3/4"PEX is certified under ASTM 877/876 and is rated for potability with NSF. It can be used in circuit lengths up to 400 ft. 3/4"PEX has wide, but not universal code acceptance.

**1/2" PEX** - This product has thicker walls when compared to the other tubings and has higher temperature and pressure ratings (180<sup>0</sup> F @ 100 psi). However the smaller size and thicker walls mean that the product is much less effective as a heat exchanger. 1/2"PEX is certified under ASTM 877/876 and is rated for potability with NSF. It can be used in circuit lengths up to 300 ft. 1/2"PEX is significantly more maneuverable than the other products and it is easier to install in tight areas. 1/2"PEX has wide, but not universal code acceptance.

**3/8" PEX** - This is our most maneuverable product, but the smaller size and thicker walls mean that the product is much less effective as a heat exchanger. The temperature and pressure ratings are (180<sup>0</sup> F @ 100 psi). 3/8"PEX is certified under ASTM 877/876 and is rated for potability with NSF. It can be used in circuit lengths up to 150 ft. 3/8"PEX has wide, but not universal code acceptance.

**OXYGEN DIFFUSION BARRIER TUBING** - This specialty product can be used in heating systems with components that are not compatible with oxygen.

Radiantec does not carry rubber tubing. Rubber tubing is the easiest product to install, but this convenience does not make up for its limited service life.

**PROPERTIES OF RADIANT HEAT EXCHANGER TUBES**

TUBING TYPE	COST per sq. ft.	HEATING OUTPUT	SERVICE LIFE	BENDING DIAMETER	TEMP & PRESS RATING
7/8" POLY PXC	Lowest	Highest	100 + years	24 inches	150° F at 50 psi
7/8" POLY PEX	Low	High	100 + years	24 inches	120° F at 100 psi
1/2" PEX	Medium	Medium	100 + years	12 inches	180° F at 100 psi
3/8" PEX	High	Low	100 + years	6 inches	180° F at 100 psi

**THE INFORMATION IN THE PREVIOUS CHART ALONG WITH OUR TWENTY FIVE YEARS OF EXPERIENCE AND RESEARCH SUGGEST THE FOLLOWING USAGES:**

**LARGE SLABS**

Any slab larger than 200 square feet will lend itself to the use of POLY PXC tubing or 3/4" PEX tubing. POLY PXC is the most economical tubing and its lower pressure rating is irrelevant because the tube will be surrounded by reinforced concrete.

**SMALLER SLABS AND THIN SLABS**

Use 1/2" PEX or 3/8" PEX.

**UNDERNEATH A JOISTED FLOOR**

Use 7/8" POLY PXC if the runs are fairly unobstructed as in new construction. Otherwise, use one of the smaller diameter tubes. For very cluttered retrofits, use 1/2" PEX.

**SNOWMELT**

Use 1/2" or 3/4" PEX.

**RETROFIT BATHROOMS**

Use 1/2" PEX or 3/8" PEX.

**CIRCUITS LENGTHS AND FLOW RATES**

It is desirable that circuit lengths be neither too long nor too short. The purpose of the tubing is to allow water (or another fluid) to pass through it and lose heat as it goes along. This heat is received by the floor which then heats the building. If the tube length is too long, there will be a tendency for the water to lose too much heat before it reaches the end of the run. The result is tubing at the end of the circuit is exposed to water that has already lost much of its heat and the tubing is then "loafing". You can make up for this by increasing the fluid velocity with a larger pump. At some point, the water becomes too turbulent. Pump work and electricity consumption become unreasonable. In extreme cases, erosion corrosion can occur (the physical wearing away of system components) because of flow that is too turbulent.

Circuit lengths which are too short tend to run in laminar flow (smooth flow) which doesn't exchange heat quite as well as a slightly turbulent flow. One nuisance of slow flow is the possibility that air bubbles could collect in some tubes and reduce effectiveness or even block flow.

The goal is to have the fluid come out of the tube within 10-15 degrees of the temperature it went in at and move at a slightly turbulent flow as it passes through. The relationships on the next page work well although deviations can be acceptable if adjustments in pump sizing are made. Call the Radiantec Company for technical assistance if these recommended lengths cause inconvenience. Radiantec Company will specify a pump that will meet your pumping requirements in the most economical manner.

Radiantec will help you figure out circuit lengths and material choices. Just call 1-800-451-7593 or send in the yellow proposal request form.

TUBE DIAMETER	MINIMUM LENGTH	MAXIMUM LENGTH	FLOW RATE
3/8"	N/A	150 ft.	.125 gpm/100 ft. of tube
1/2"	100 ft.	300 ft.	.25 gpm/100 ft. of tube
7/8"	200 ft.	400 ft.	.5 gpm/100 ft. of tube

### MAXIMUM FLOOR TEMPERATURES

Floors should not exceed 90 degrees Fahrenheit on a routine basis and should never exceed 100 degrees Fahrenheit.

### RECOMMENDED TUBE SPACING

These tube spacings will provide comfortable even heat within the limits of the fluid temperatures that are desirable.

TUBE DIAMETER	RECOMMENDED SPACING
3/8"	6" - 8"
1/2"	8" - 12"
7/8"	12" - 16"

### CALCULATE THE AMOUNT OF TUBING REQUIRED

Determine the total length of tubing needed by multiplying the floor area (in square feet) by the multiplier shown for your tube spacing.

*If the tubing will be spaced at 16" on center, multiply the floor area by .75.*

If the tubing will be spaced at 16" on center, multiply the floor area by .75

SPACING MULTIPLIER	
16" on center	.75
12" on center	1.00
8" on center	1.50
6" on center	2.00

**EXAMPLE:** A 1,000 square ft. area requires 750 ft. of tubing if spaced 16" on center (1,000 x .75)

## INSTALLATION SUGGESTIONS

**Important Notice**—These installation suggestions are of a general nature and they are based upon our 25 years of experience. It is important to understand that every project is a little different, and it is the role of the designer to incorporate all available information into the project. Radiantec makes no representation that these general suggestions are applicable to any particular project. Radiantec takes no responsibility for the design of any heating project. Radiantec makes no representation about the completeness of the information provided. The designer must consider important factors such as architecture, state and local codes, and customer preferences.

### LOOK ON THE INTERNET FOR THE FOLLOWING SUBJECTS

[www.radiantec.com](http://www.radiantec.com) (select installation manual)  
or call 1-800-451-7593

#### INSTALLATION SUPPLEMENT 250—Install radiant heating tubes within a slab

Layout suggestions, concrete reinforcing, installation manifolds, pressure testing, tube spacing, insulation, etc. Use for slab on grade, suspended slabs, and topping slabs.

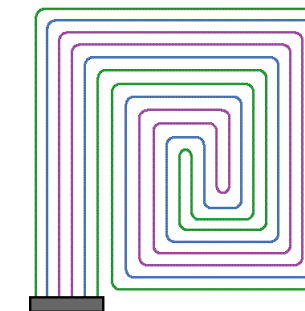
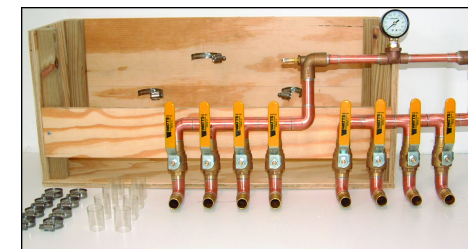

#### INSTALLATION SUPPLEMENT 260—Install radiant heating tubes within joists

Layout suggestions, aluminum plates, manifolds, tube spacing, product selection.

