

## CONTROLS

This supplement presents a layman's language narrative about Radiantec Company controls, their design and their installation. This supplement is not intended to provide complete instructions and reference must be made to the manufacturer's installation instructions that are provided with individual units.

There are inherent risks associated with installing and using electrical components. Installation of electrical components should only be done by those who have a satisfactory understanding of these risks and who are qualified to do so. Also, any applicable codes must be complied with. This document is provided for informational purposes only and Radiantec is not responsible for damages resulting from improper installation or misuse of its products.

## PURPOSE OF RADIANTEC CONTROLS

The purpose of Radiantec controls is to sense the comfort level of an area and activate heating equipment whenever the heating level is inadequate. The control will then deactivate the heating equipment when the heating requirement is satisfied.

Radiantec Company prefers simple controls that are low in cost and highly reliable. It is our opinion that these simple, low cost controls work very well in most residential buildings that are energy efficient.

### THERMOSTAT

A Radiantec thermostat will sense and display the ambient temperature and then operate a control whenever ambient temperatures fall below the set point. The thermostat will be adjustable and may have different temperature options and setbacks for different times of day or days of the week. Radiantec doesn't typically recommend the use of so-called "set-back" thermostats for radiant heat because studies show that leaving the thermostat at a constant setting is the most cost effective way to operate your radiant system. We do offer them if you feel that you truly need or want one.



### RELAY

The relay box is like a central command center. The thermostat and pump are both wired to the relay box. When the thermostat senses a need for heat, it sends a signal to the relay box which in turn, sends power to activate the pump which will cause hot water to flow from the heating unit to the tubing underneath the floor. The tubing then transfers heat to the floor which then heats the selected area.



## HEATING UNIT

Heating units either “maintain temperature” or they are “cold start.” If they maintain temperature, they are always on and ready to provide heat. They will have their own internal control, typically referred to as an aquastat. A system using a tank-style domestic water heater is one example of a heating unit that maintains temperature. They are always ready to provide heat promptly. It is important to select a unit with low standby losses if it will maintain temperature.

If they are “cold start,” they will be off unless called to operate by the thermostat and relay. A large percentage of new boilers today are of the cold start variety.

## OPERATION

You should plan for two dedicated circuits for your system, generally; one 15-amp breaker for the heating unit and one 15-amp breaker for the relay and pumps. Since the pumps draw about 1 amp a piece, a larger breaker may be needed if you have a lot of pumps. Some people choose to put all of the pumps and heating unit on one breaker which is acceptable as well; the choice is up to you and your electrician.

Electricity is supplied at 120 Volts AC from your main electrical panel. The transformer in the relay box will lower the voltage to 24 volts for the thermostats and relays. When the thermostat senses a need for heat, the circuit through the thermostat is closed and 24 volt AC signals the relay to close the 110 volt circuit to the pump. The pump comes on and the heating system operates until the thermostat is satisfied and shuts the system off.

If the heating unit is of the cold start type, it is also wired to the relay box so that the unit is activated when the thermostat signals the pump to come on.

## WIRING RADIANTEC THERMOSTATS TO THE RELAY BOX

Radiantec offers several different thermostats and temperature sensing devices that need to be wired to the relay box.

### Wall Thermostat

A standard wall thermostat reads the air temperature and activates a pump when the air temperature falls below the set-point. This is the most common way to control the comfort level with any heating system. Radiantec offers the Azel D-135 which is digital but not programmable. It does not contain mercury so it is environmentally friendly. 18-22 gauge 4-wire is recommended for the thermostat connections (18 gauge is the most common). Two of the wires are needed to supply power for the digital portion of the thermostat and two wires are needed to activate the pump. Schematic 1 shows the wiring of the D-135 to the SP-81 Relay box and Schematic 2 shows the wiring of the D-135 to the SP-82, SP-83, SP-84, SP-85, and SP-86 Relay boxes. If you are wiring more than 2 thermostats, you will find that the 24V connections are not large enough to accommodate all of the wires. You will need to “gang” all of the wires together with a wire-nut and then bring only one of them back to the relay. **Be sure to review the thermostat and relay box instructions for complete installation recommendations. Many codes require that this work be done by a professional.**

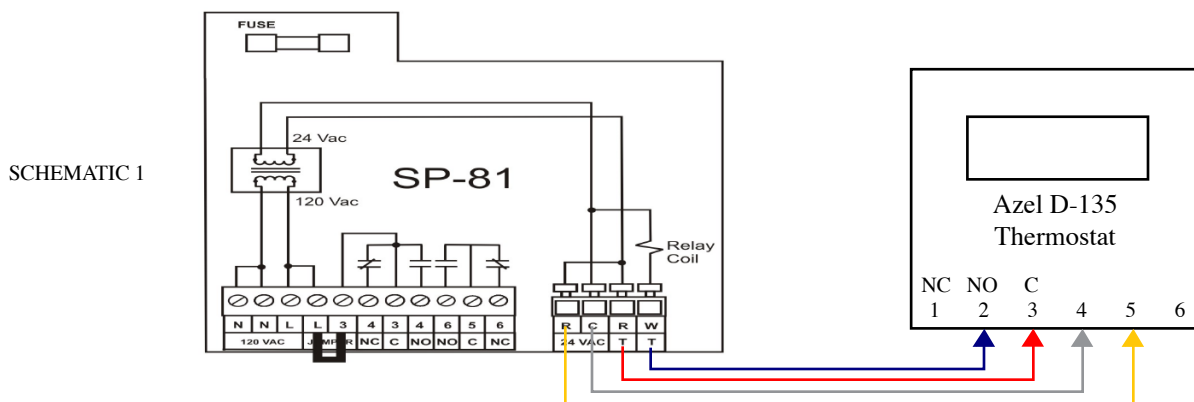

SCHEMATIC 2

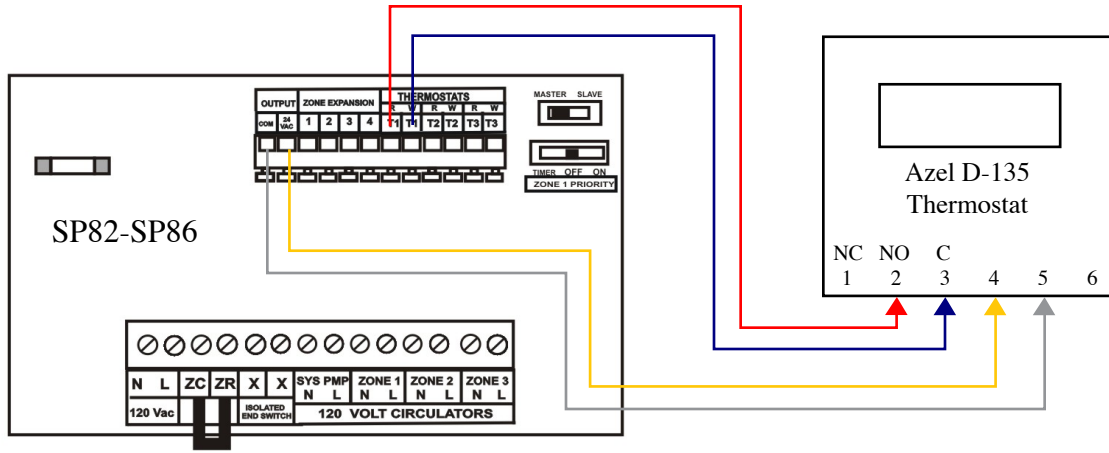

## Floor Control

A floor control uses a bulb-type thermistor (or probe) which is secured to the floor and is wired back to the thermostat or control box. The thermistor reads the floor temperature and activates a pump when the floor temperature falls below the set-point.

A floor control is typically used if there is something that could override a standard wall thermostat. For example, let's consider a great-room that typically has high ceilings and a lot of windows. This is typically considered a high heat-loss area. During the day when the sun is shining, the sun will override the wall thermostat and your floor will cool off. As soon as the sun goes down, the windows that let all of the sunshine in will now let all of the heat back out (even the best windows on the market only have an R-value of about 5), quickly cooling the room. Now you have a floor that is cold, a room that is cold, and it will take quite some time to warm the floor back up. A floor control will allow you to maintain a comfortable floor temperature all day so that as soon as the sun goes down, your floor is warm and ready to provide heat.

A floor control is also used when the primary purpose of the radiant heat is floor warming. Some people may want to warm a tile floor; others may want to simply make a room more comfortable. The floor sensor will allow the floor to come up to a comfortable and constant temperature while the primary heating system takes care of the air temperature. Radiantec technicians can help you decide if you need a floor sensor in a particular area.

One floor control that Radiantec offers is the Azel D26F. It has a digital read-out and it wires back to a relay box. Schematic 3 shows how the D26F is wired to the SP81 and Schematic 4 shows how the D26F is wired to the SP82 thru SP86. Use 18-22 gauge 4 wire (18 gauge is the most common) for the connections from the relay box to the floor control. Use conventional 18 gauge wire to extend the probe if the 10' lead that is provided is too short. **Be sure to review the relay box and floor control instructions for complete installation recommendations.**

SCHEMATIC 3

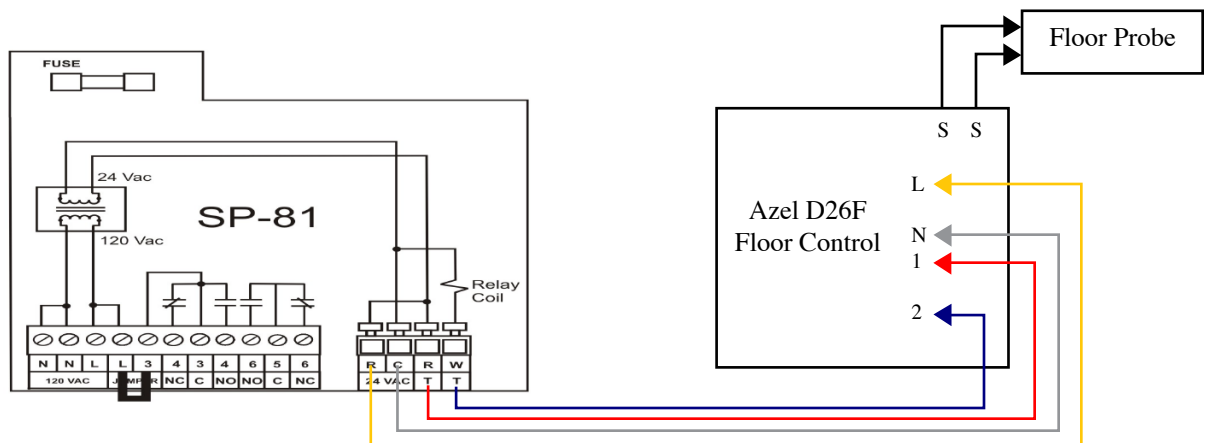

SCHEMATIC 4

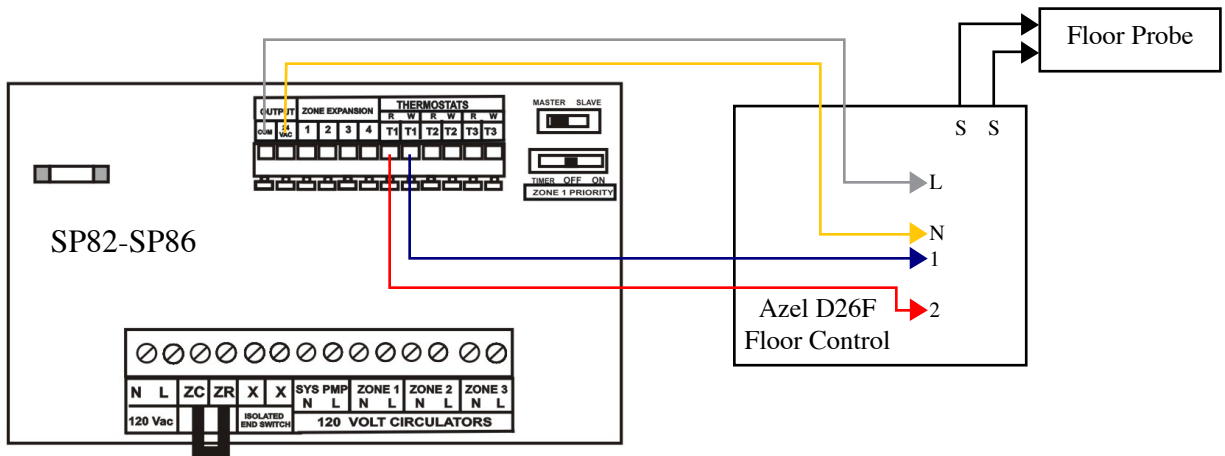

## INSTALLING THE SENSOR INTO THE FLOOR

**Method 1** shows how the sensor may be installed in a concrete slab. Keep in mind that the sensor should be retrievable but it's not mandatory that it is.

This method depicts a piece of tubing or conduit that is installed as part of the concrete pour. The sensor is then inserted into the "sleeve" once you are ready to install the control.

The most common method is to cut 3'-4' off of the end of a roll of tubing. At the slab manifold, install this tubing so that one end will be down into the slab and the other is coming into the manifold box. Be sure to tape the end that will be in the concrete.

If the slab was poured without this detail, you can simply place the sensor on the surface of the slab and cover it with a piece of insulation.

**Method 2** shows a sensor installed in a thin-set for a tile installation. Be certain that the sensor is installed 1/2 way between two runs of tubing. The only problem with this installation method is that the sensor is not retrievable. If the sensor ever needs to be replaced, you will have to consider one of the other installation methods. You may want to consider another method from the onset, such as method 5.

**Method 3** shows an above floor installation of the sensor. A small groove is cut into the subfloor for the sensor and the wire. Be sure that you have a long enough lead for your sensor wire so that there is no need for a splice under the floor. As with method 2, this sensor will not be retrievable and you may want to consider method 5.

**Method 4** is very similar to method 3 except the groove is cut into a thick flooring material instead of the subfloor. If your flooring material is thick enough, this is a popular installation method.

**Method 5** is the most popular installation method for staple-up systems. Cut a piece of 1" rigid insulation into a 4"x4" square and cut a groove deep enough into it so that the sensor is flush to the insulation. Now, sandwich the sensor between the insulation and the subfloor. Make sure to do this in a place where the sensor is contacting the sub-floor and not one of the aluminum heat emission fins. A structural adhesive may be used to secure the foam to the sub-floor.

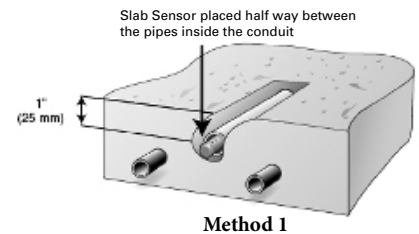

Method 1

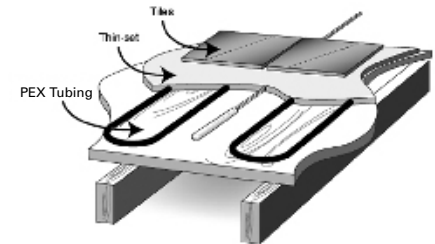

Method 2

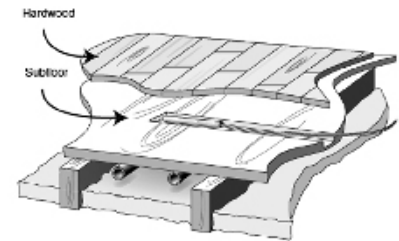

Method 3

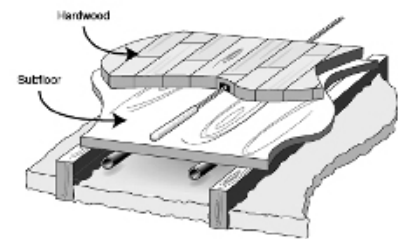

Method 4

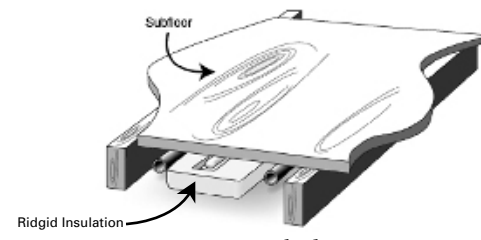

Method 5

## Digital Temperature Gauge

Outgoing and returning water temperatures are very important pieces of information when troubleshooting a hydronic heating system. Radiantec provides the DS-60P which is manufactured by Azel, for this purpose.

The digital display comes with two temperature sensing probes; one is attached to the copper supply coming out of your heating source (if you are using a boiler with a mixing valve, this supply probe should be located between the mixing valve and your pumps) and the other is attached to the copper line that returns to your heating source. You can simply use a plastic zip tie or a stainless steel hose clamp to secure the probes to the copper. Some people will wrap the probe with tinfoil but this isn't really necessary. The probes come with a short piece of wire that will need to be extended. Use 18-22 gauge 2 wire thermostat wire for this (18 gauge is standard).

The actual display can be powered in one of two ways. It can be battery powered (which is provided) or it can be powered by 24v. Most people prefer to power the display with 24v because once it's wired, you are done; there is no battery to change.

All of the Azel relay boxes Radiantec supplies may be used to supply the necessary 24v power. To make these connections, you should use 18-22 gauge 2 wire thermostat wire. Schematic 5 shows how to wire the DS-60P to the SP-81 relay box and Schematic 6 shows how to wire it to the SP-82 through SP-86 relay boxes.

The digital readout should show the temperatures in Fahrenheit. If it is in Celsius, you will need to flip a switch inside of the unit. To learn how this is done, refer to the manufacturer's instructions.

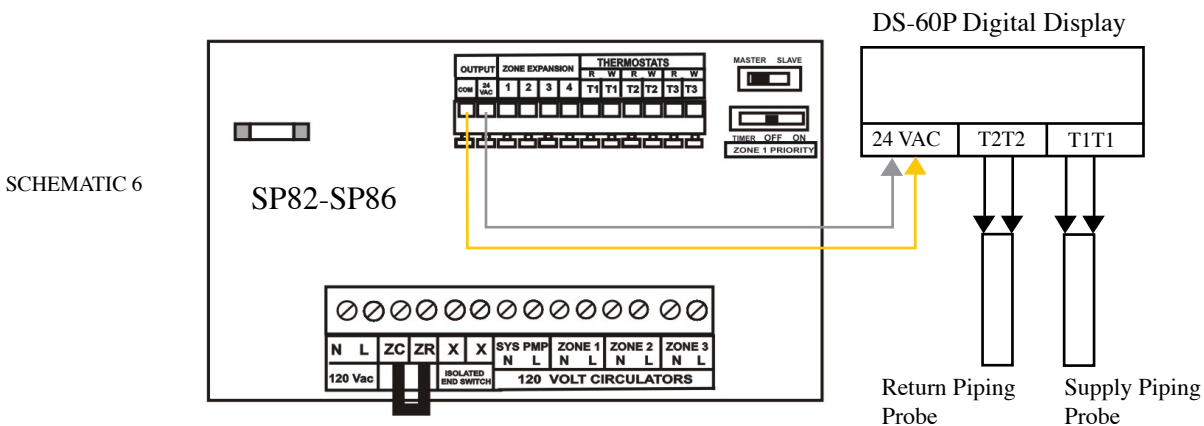
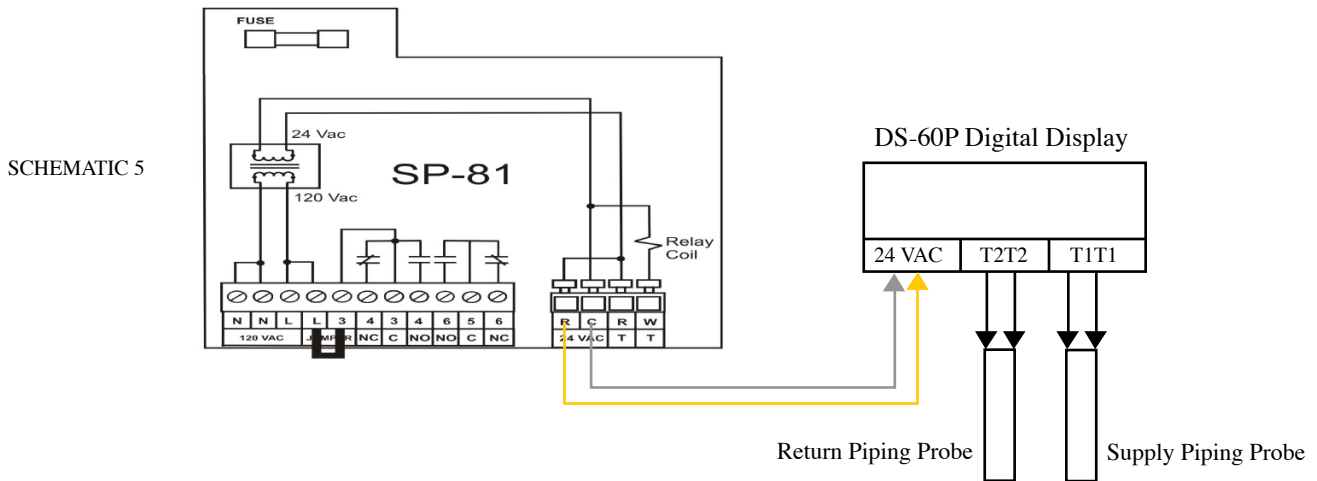

## WIRING THE RELAY BOX

This section will take you through the process of wiring your relay box to the power supply, your pumps to the relay box, and your heating source to the relay box (if a boiler is used). **All local building codes must be followed and this work may be better suited for a licensed professional.**

Some people use 10 to 18 gauge Romex (with 12 or 14 gauge being the most common) to supply power from the breaker box to the relay box and to supply power to the pumps from the relay box. Many codes, however, will dictate that you should use a shielded BX Cable instead (also referred to as armored cable or metal-clad cable). A quick consultation with someone at an electrical supply house will typically result in the use of the proper material.

### Wiring the pumps

Refer to the pump instructions for the actual wiring to the pump. Some of the pumps will simply have wire terminals designated as L (hot), N (neutral), and Ground, while other pumps may have two unlabeled wires.

For the pumps that have the two wires, you can simply choose one for the hot and one for the neutral; it doesn't matter which one is which. For this pump, there will be a green grounding screw where you will connect your grounding wire.

### Grounding

Since the relay box is plastic, it cannot be used for the ground. The wire that you ran from the breaker box will be grounded at the breaker box. To ground the pumps, you will need to wire-nut together the ground wire from the breaker box to the ground wire(s) coming from the pump(s).

### Wiring instructions and schematics

Schematic 7 shows how to wire the SP-81 for a Direct, Indirect, or Closed System that uses a domestic water heater as the heating source. Please note that with an Indirect System, both pumps (the heating zone and the heat exchanger pump) need to come on simultaneously and are wired into the same set of contacts.

Schematic 8 shows how to wire the SP-81 for a Closed System using a cold-start boiler (most of the new boilers on the market today are of the cold-start variety). Cold-start simply means that they only come on when there is a call for heat (unlike water heaters that constantly maintain a certain temperature). With a cold-start boiler, we need to tell it when to turn on and this is done by wiring it to the relay box. Make the connection as shown in the diagram using 18-22 gauge low-voltage wire.

Schematic 9 shows how to wire the pumps and the SP-82, SP-83, SP-84, SP-85, and SP-86 relay boxes for a Direct or Closed System that uses a domestic water heater as the heating source.

Schematic 10 shows how to wire the pumps, boiler, and the SP-82, SP-83, SP-84, SP-85, and SP-86 relay boxes for a Closed System using a cold start boiler (most of the new boilers on the market today are of the cold-start variety). Cold-start simply means that they only come on when there is a call for heat (unlike water heaters that constantly maintain a certain temperature). With a cold-start boiler, we need to tell it when to turn on and this is done by wiring it to the relay box. Make the connection as shown in the diagram using 18-22 gauge low-voltage wire.

# Azet SP-81 Wiring Diagram for Direct, Indirect, and Closed Systems Using a Domestic Water Heater

SCHEMATIC 7

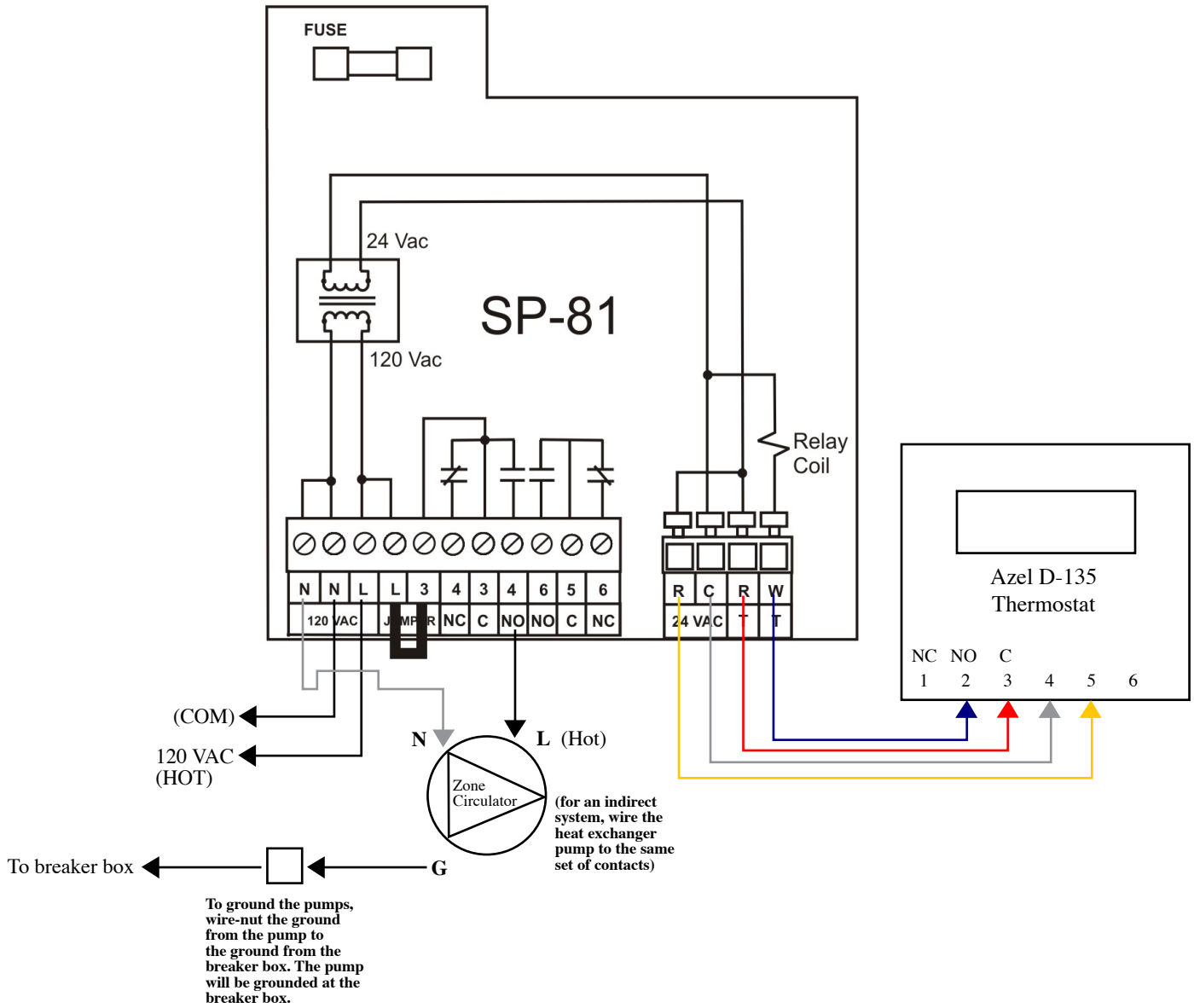

# Azet SP-81 Wiring Diagram for Closed Systems Using a Cold-Start Boiler

SCHEMATIC 8

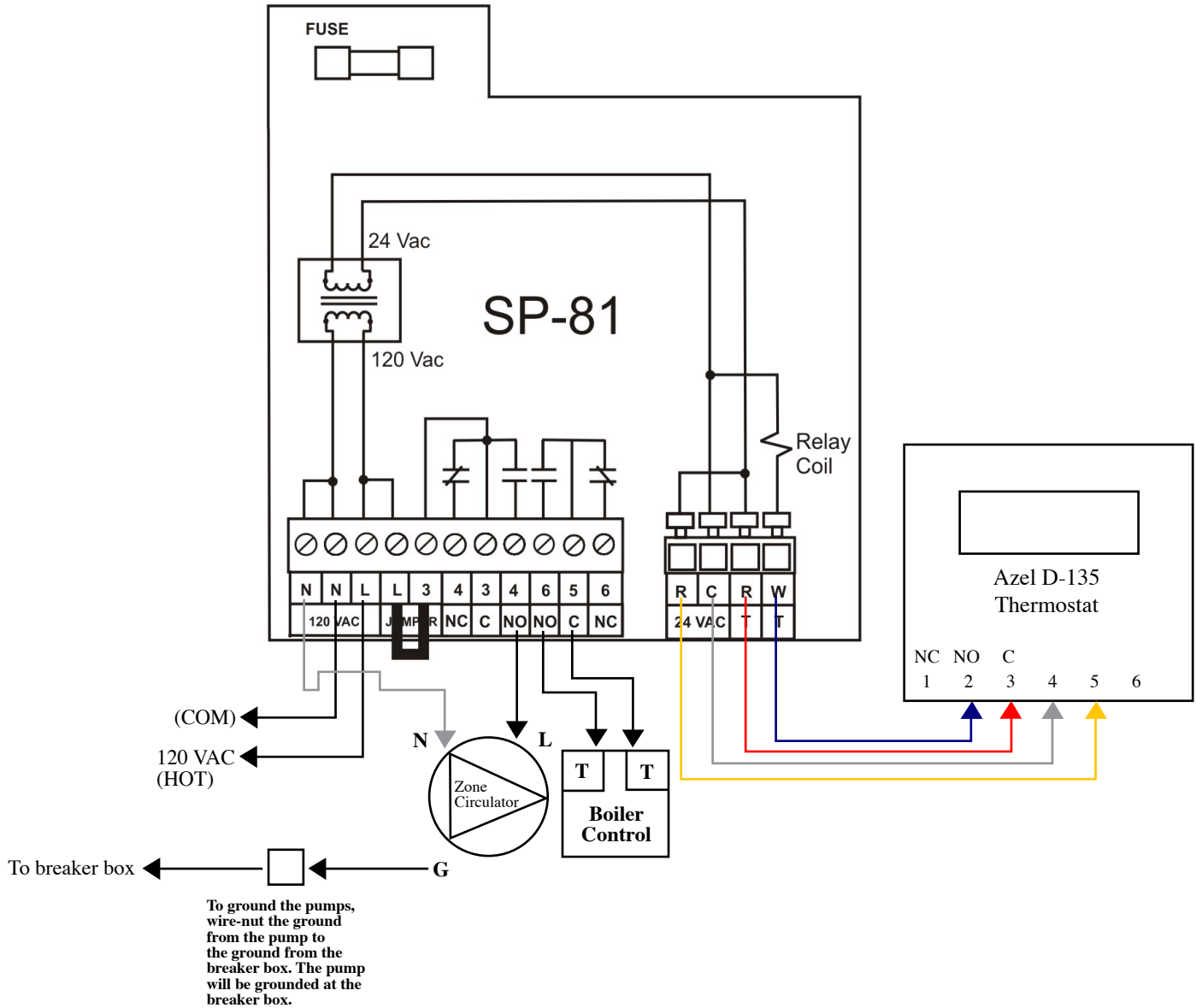

# Azet SP-81, SP-83, SP-84, SP-85, SP-86 Wiring Diagram for Direct and Closed Systems Using a Domestic Water Heater

SCHEMATIC 9

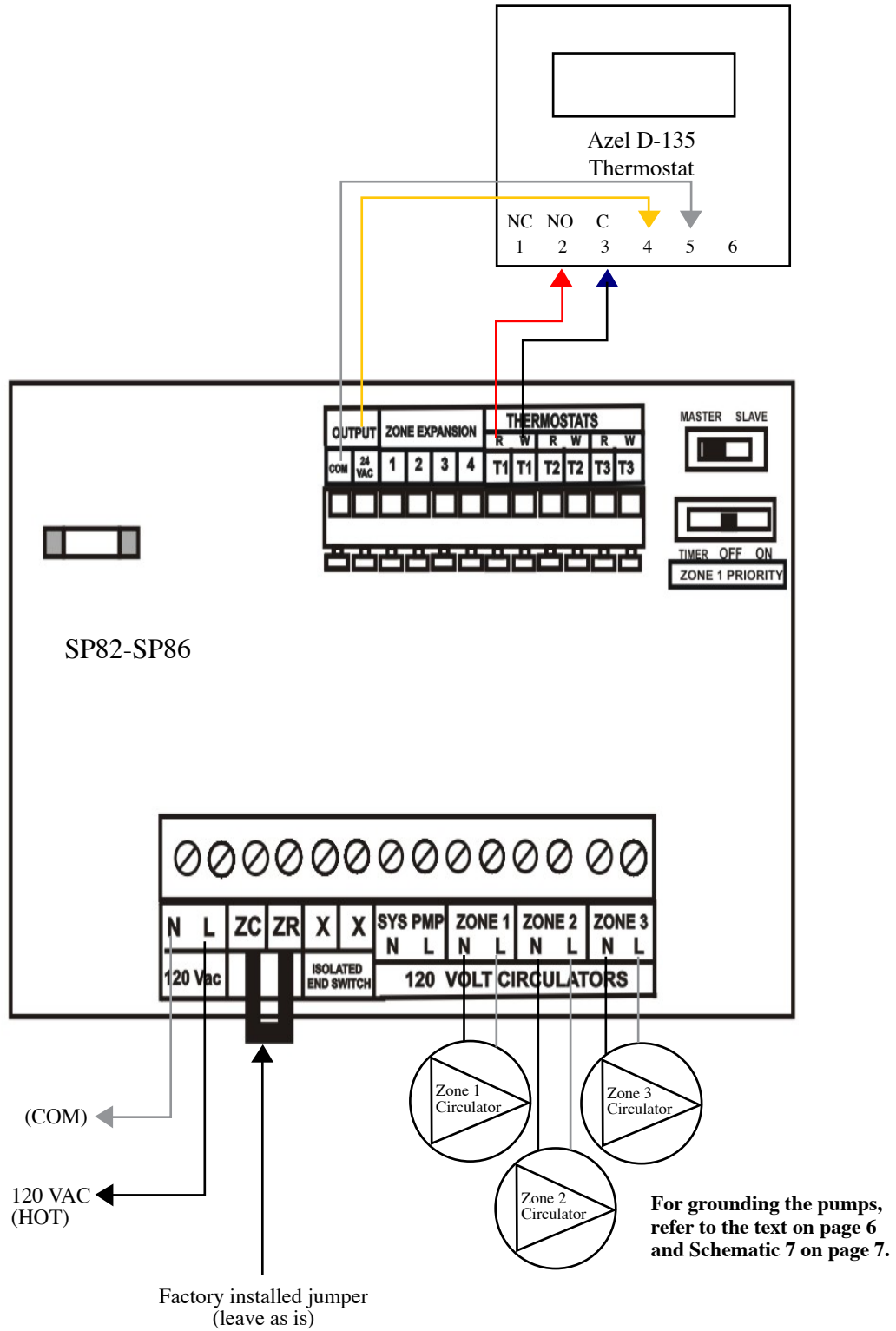

# Azel SP-81, SP-83, SP-84, SP-85, SP-86 Wiring Diagram for Closed Systems Using a Cold-Start Boiler

SCHEMATIC 10

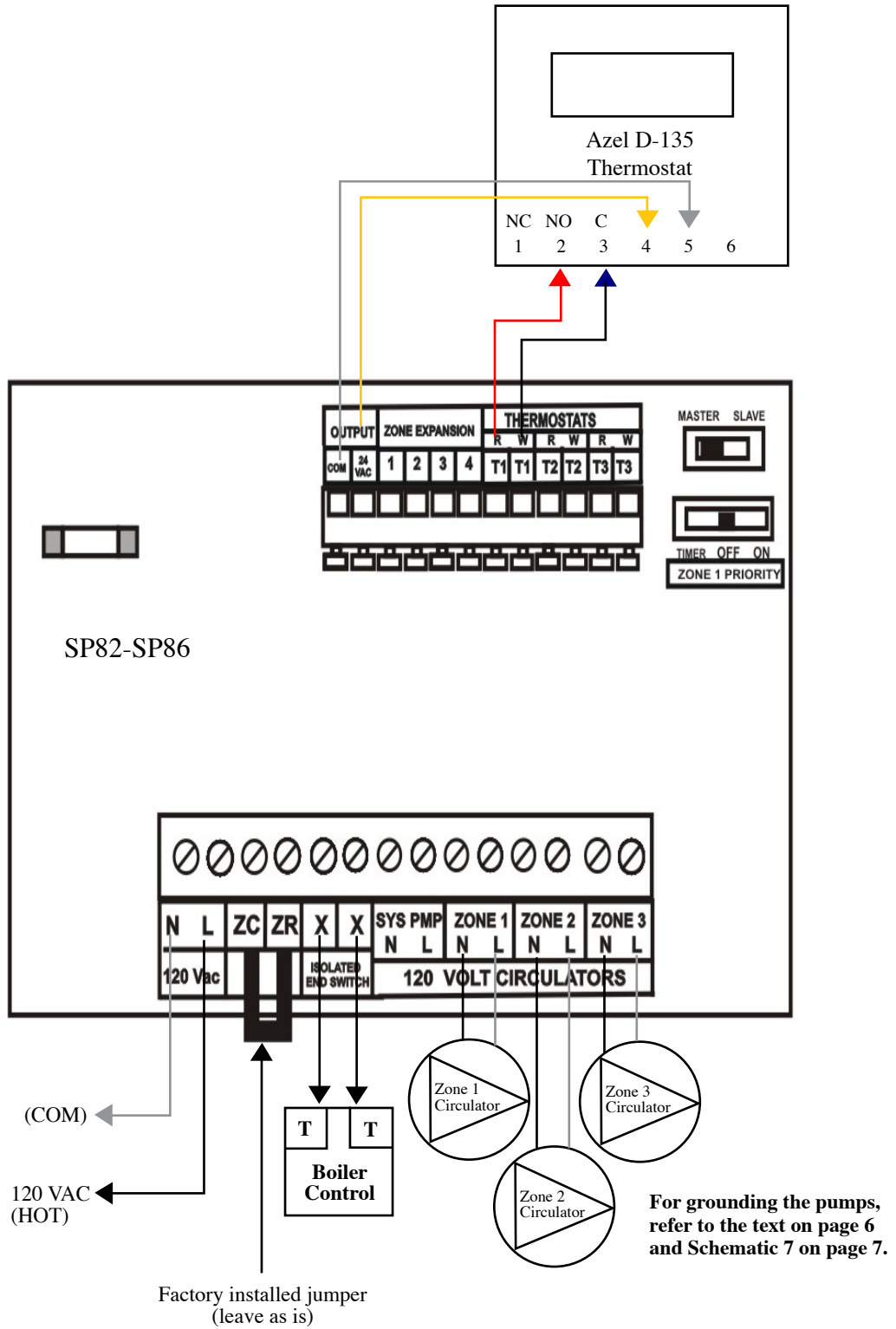

# Azet SP-81, SP-83, SP-84, SP-85, SP-86 Wiring Diagram for Indirect Systems Using a Domestic Water Heater

SCHEMATIC 11

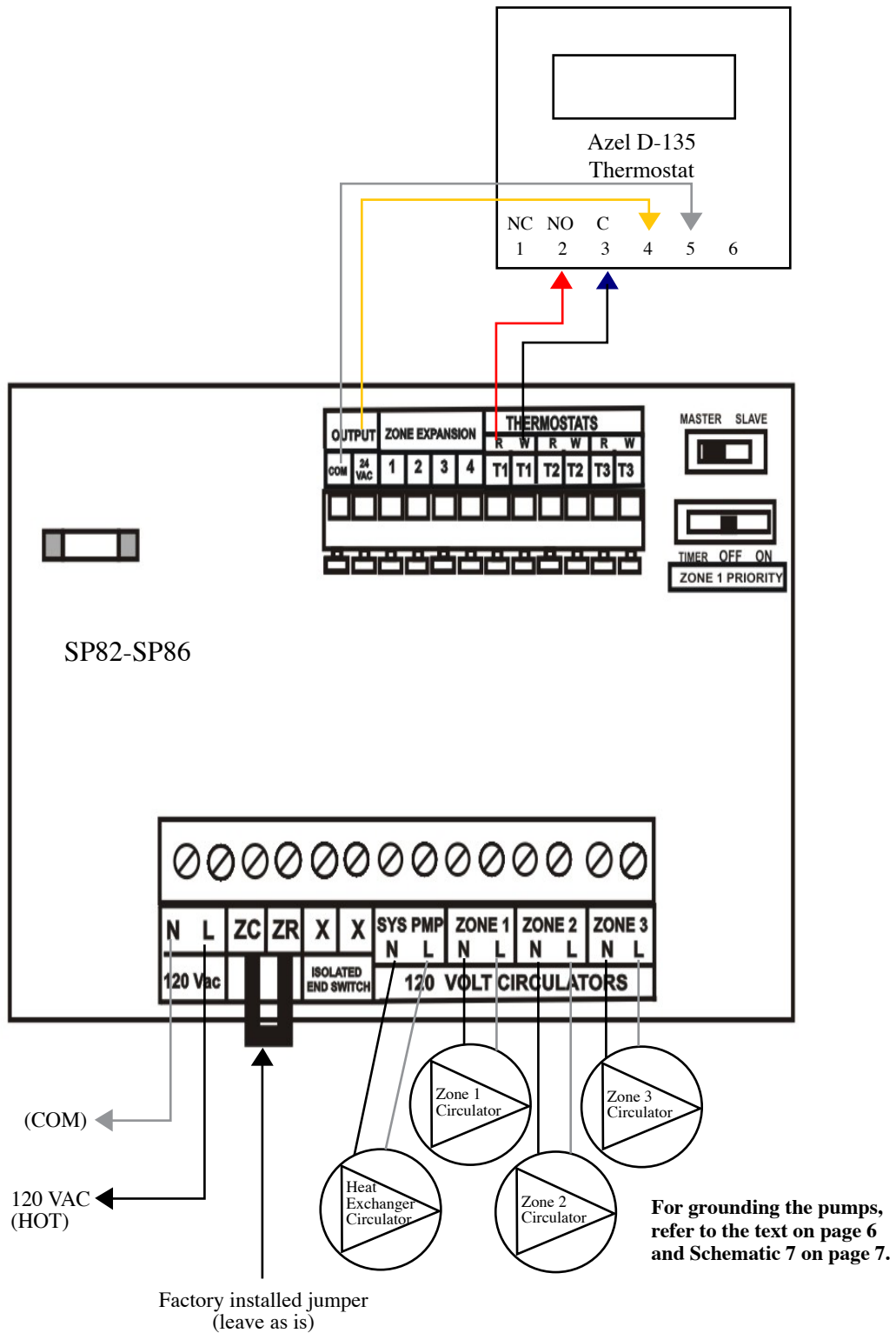

## Wiring Diagram for DST-777 Floor Control for a Direct System or Closed System Using a Domestic Water Heater

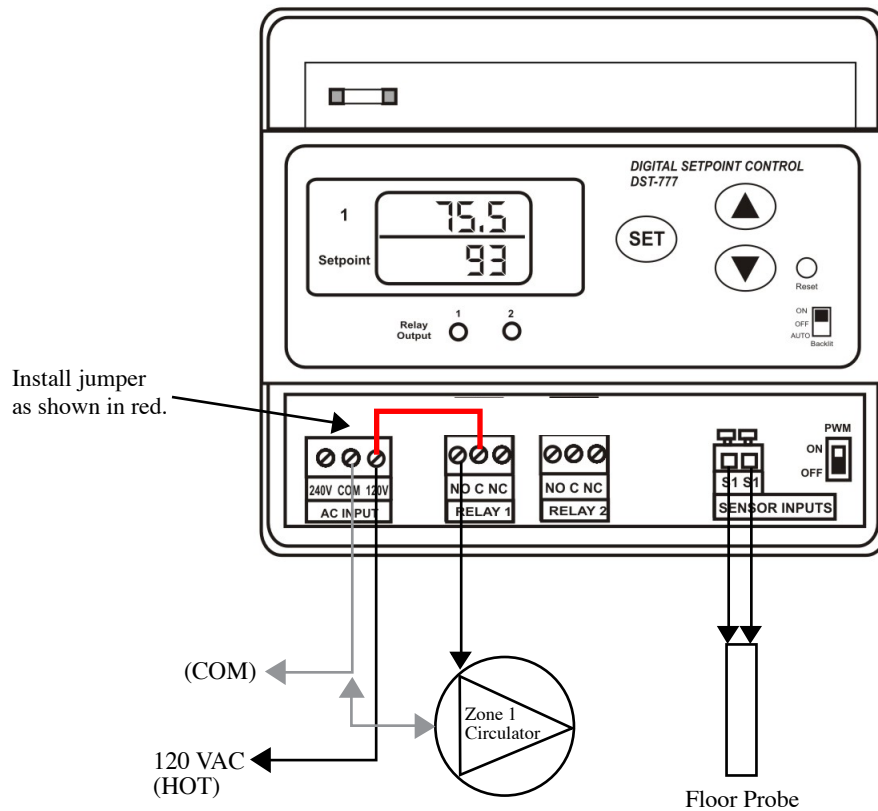

## Wiring Diagram for DST-777 Floor Control for a Closed System Using a Cold-Start Boiler

